



**INTERNATIONAL JOURNAL OF ENGINEERING SCIENCES & RESEARCH
TECHNOLOGY**

DESIGN AND DEVELOPMENT OF MOTHER MOULD OF HYDRAULIC PRESS

Vysakh.V*

*Department Of Mechanical Engineering Sri Sakthi Institute Of Engineering And Technology
Coimbatore, India

ABSTRACT

Accurate die fixing is an important stage of the hydraulic press with the precised value of clearance. At present the hydraulic press depend on the fixing of die inside the mould cavity with help of mechanical wedges. This kind of die fixing take around four hours and three men for fixing it after every cycle to produce a limited number of bricks. This project is mainly concentrated to avoid the time consumption and reduce the number of man power required to fix the die. For that the wedges can be replaced with the help of pneumatic cylinder having the capacity to withstand 200 bar pressure to lock the die. The drafting is done by using the solidworks (2012) software and the structural analysis is done by using ANSYS workbench14.0 according to the standards. The bill of materials and cost estimation are prepared. The cost of manufacturing is estimated as Rs. 13,617 including all allowances.

KEYWORDS: hydraulic press.

INTRODUCTION

The main objectives of this paper are as follows

- To design the mother mould of hydraulic press.
- To reduce the manpower required for fixing the die inside the mother mould by pneumatic cylinders.
- To reduce the time consumption for die fixing in mother mould with the replacement of the pneumatic cylinders.

The main scope of this paper as follows

The die fixing time can be reduced by changing the method of fixing die inside the cavity. Now the company use the wedge system to fix the die to the mother mould. By changing wedge fixing process by any one of the alternative methods may lead to reduce the time consumption and also help to reduce the manpower required to fix the die at the exact position.

MATERIALS AND METHODS

This chapter explains the various methodologies followed in designing phase. The various parts that are used to assemble the “mother mould” are drafted according to the standard dimensions by using the solid works (2012) and designing of that parts are discussed in this chapter.

EXISTING MODEL OF THE MOTHER MOULD

Based on this model parts for constructing the machine are selected with proper dimension by using design calculations and manufacturing drawings also drawn. The existing model diagram is drawn according to the standards, it gives the clear idea about the mother mould. Die fixing methods can be easily visible. Following that the components and its material specifications are given in detail. The rectangular plates dimensions are also mentioned in detailed. The die which is made by high carbon high chromium steel or stainless steel and the remaining are all made of mild steel. The rectangular plates are filled between the space of die and the wedges. The rectangular plates dimensions are varied because of the variation in the die dimensions in each cycles.

DESIGN CALCULATIONS

Clamping Force Calculation in Existing System

There are two wedges used for the locking of the die. The wedges having the dimensions of 15x25 mm and 34x 15 mm. These two wedges are shown in Figs.2.1 and 2.2 are capable of locking the die inside the mould cavity without changing the clearance value of the die.

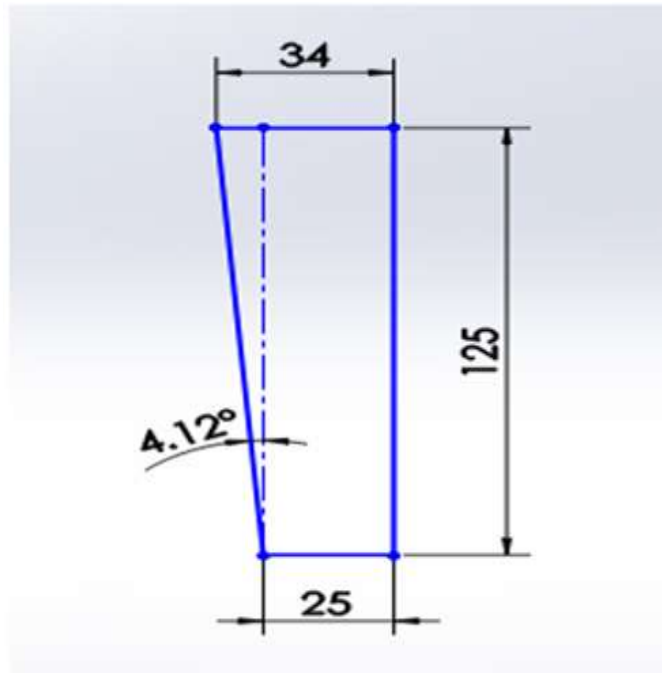

Fig.2.1 Wedge having the cross section of 15 x 25 mm

The hypotenuse value is unknown one which can be calculated by Pythagoras theorem, from Fig.2.1

$$\begin{aligned} \text{Hypotenuse} &= \sqrt{165^2 + 10^2} \\ &= 165.302 \text{ mm} \end{aligned}$$

Calculation of the inclined angle of the wedge

$$\sin \theta_1 = \frac{10}{165.302}$$

$$\theta_1 = 3.468^\circ$$

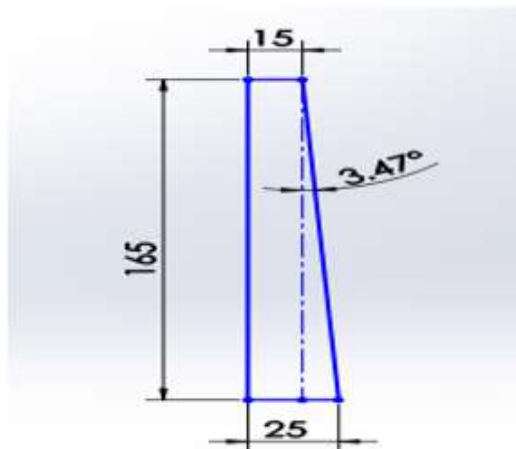

Fig.2.2 Wedge having the cross section of 34 x 25 mm

for wedge 2

$$\begin{aligned} \text{Hypotenuse} &= \sqrt{125^2 + 9^2} \\ &= 125.32 \text{ mm} \end{aligned}$$

Calculation of the inclined angle of the wedge

$$\sin \theta_2 = \frac{9}{125.32}$$

$$\theta_2 = 4.118^\circ$$

The Clamping Force Acted on the Die

Find out the clamping force of the wedge is helpful to find the least necessary force to clamp the die by the cylinder which is going to replace it. For that consider the free body diagram shown in the Fig.2.3 in which N_R is the normal force acted against the weight of the surface of contact. W is the body force acting vertically downwards and F is the frictional force acting between the two bodies. μ is the coefficient of friction acted between the two bodies.

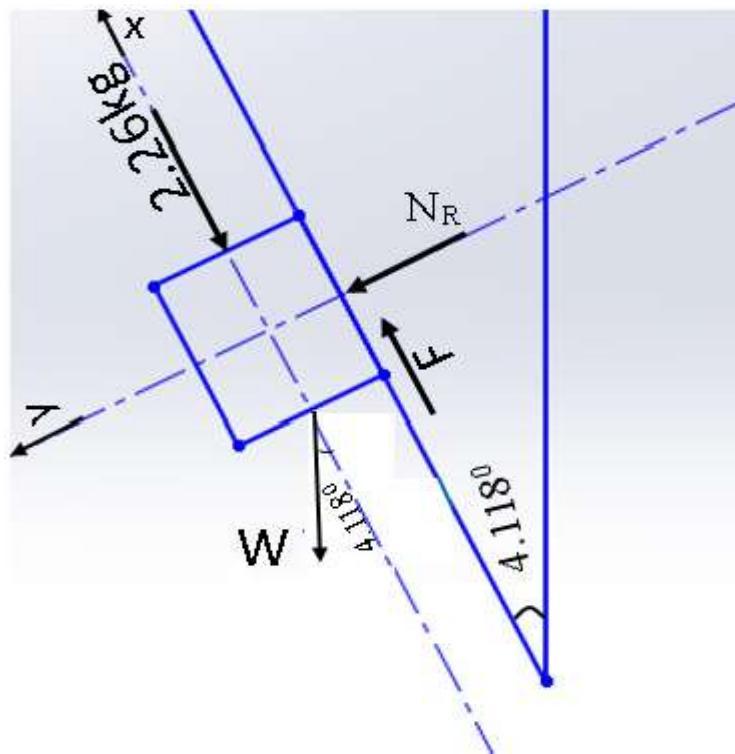

Fig.2.3 Free body diagram of the wedges

where,

N_R – Normal reaction force

μ - Coefficient of friction

W – Weight of the body which vertically act downwards

F – Force acted due to frictional force

$$\begin{aligned} \Sigma f_y &= 0 & [3] \\ \Sigma f_x &= 0 \\ \Sigma f_x &= \text{Applied force + weight of the} \end{aligned}$$

$$\begin{aligned} \text{wedge - F} &= - 22.170 - 114.051 \times \cos (265.882) + F \\ &= - 13.97 \text{ N} + F \\ F &= 13.97 \text{ N} \end{aligned}$$

The force against the motion (F) is equal to the product of normal force (N_R) and the coefficient of friction (μ). Let us take 0.3 as the coefficient of friction value.

$$\begin{aligned} N_R \times \mu &= 13.97 \text{ N} \\ N_R &= 46.56 \text{ N} \end{aligned}$$

46.56 N force acted towards the walls of the mould

Forces acted inside the die calculated by take the maximum pressure value as 200 bar

$$\begin{aligned} \text{Total area of die} &= 48400 \text{ mm}^2 \\ \text{Pressure 200 bar} &= 2039432 \text{ kg / m}^2 \\ \text{Force acted on wall} &= \text{pressure} \times \text{area} \\ &= 2039432 \times 0.048400 \\ &= 98.708 \times 10^3 \text{ kg} \\ &= 98.708 \times 10^3 \times 9.81 \\ &= 968.33 \times 10^3 \text{ N} \end{aligned}$$

Tensile strength towards the wall of die

$$\begin{aligned} \sigma &= 2F/\pi ah \\ \text{where, } a &= 220 \text{ mm} \\ h &= 140 \text{ mm} \\ &= \frac{2 \times 968.33 \times 10^3}{\pi \times 220 \times 140} \\ &= 20.014 \text{ N / mm}^2 \end{aligned}$$

Selection of Pneumatic Cylinder

The selection of the pneumatic cylinder is done according to the theoretical pull force and theoretical push forces.

$$\text{theoretical push force, } F = \pi \left(\frac{D^2}{4} - \frac{d^2}{4} \right) P$$

where, F is force in lb [4]

D is the cylinder bore in inches
P is the pressure in psi

$$\text{Theoretical pull force, } F = \pi \left(\frac{D^2}{4} - \frac{d^2}{4} \right) P$$

Where, d is the piston rod diameter in inches

ANALYSIS

The structural analysis are carried out by using ANSYS workbench 14.0 the analysis results are as follows. The die having pressure of 50 bar acted towards the die wall is shown in the Fig.3.1 and the die having a pressure of 100bar pressure is shown in the Fig.3.2. The Fig.3.3 and 3.4 are shows the existing system having pressure acted by 50bar and 100bar. The analysis results shows the positive results because of the small deflections are obtained in the results.

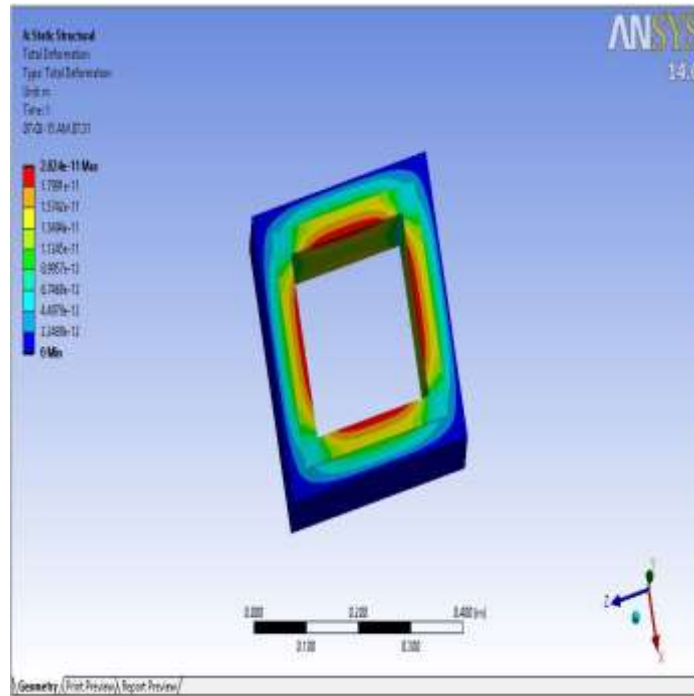

Fig.3.1 Analysis of die for 50 bar pressure

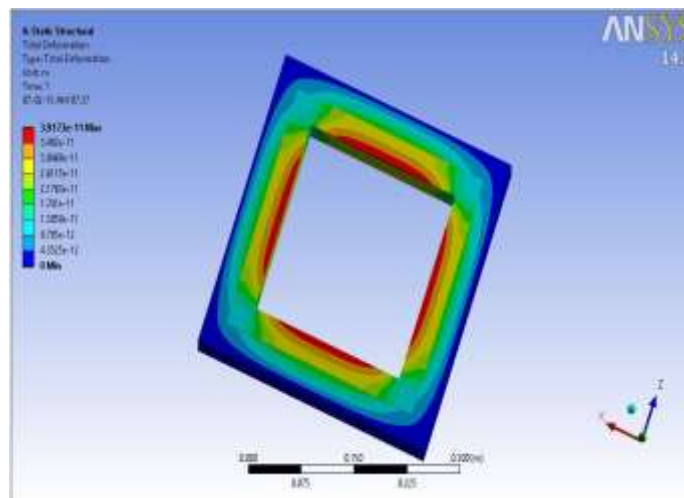

Fig.3.2 Analysis of die for 100 bar pressure

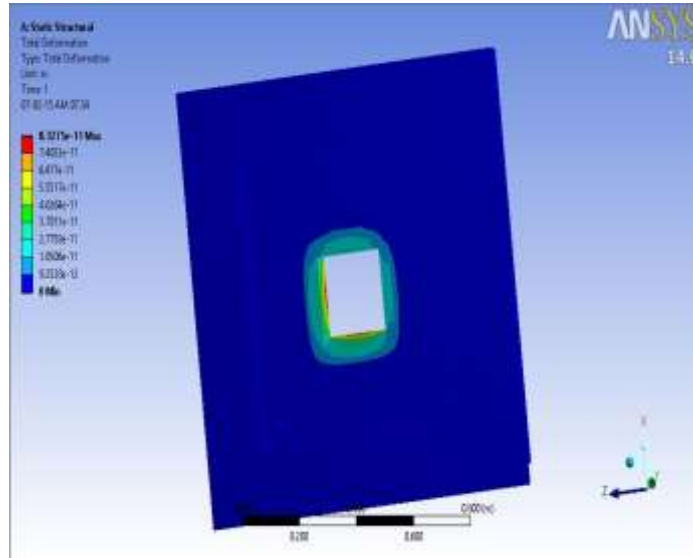

Fig.3.3 Analysis of mould for 50 bar pressure

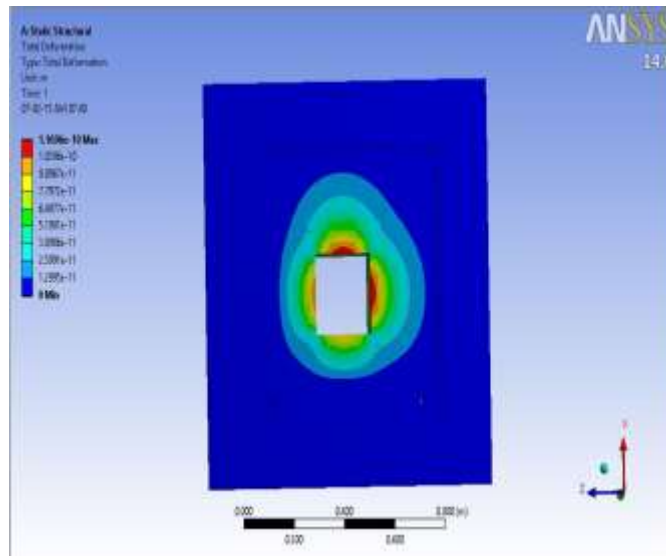

Fig 3.4 Analysis of mould for 100 bar pressure

BILL OF MATERIALS

The bill of materials are listed in the table 4.1. From the bill of materials number of items its quantity and the material used to manufacture can easily identified.

Table 4.1 Bill of materials

Item	Description	Quantity	Material
1	Mould	1	Mild steel
2	Die	1	Stainless steel

3	Rectangular plates	4	Mild steel
4	Hydraulic cylinder	2	-

COST ESTIMATION

The cost of manufacturing the prototype of mother mould of hydraulic press is given in the tables 4.2 from the table the cost for the material purchase can founded as Rs.6,957 and the labour cost as Rs.1,360.

Table 4.2 Detailed cost statement

S.No.	Items	Unit of measure	Qty.	Rate / unit (Rs.)	Amount
1	Mould	kg	19	70	1,330
2	Die	kg	4	290	1,160
3	L Bracket	kg	2	70	140
4	Rectangular plate	kg	1.5	85	127
5	Hydraulic cylinder	Nos	2	1,450	2,900
6	Sheet metal	kg	2	75	150
7	Direction control valve and control setup	Nos	1	1,150	1,150
				Total	6,957
	Labour cost				
	Manufacturing cost	Per hour	85	16	1,360

COST STATEMENT

The cost estimation for the manufacturing of the mother mould of hydraulic press is obtained from the Table 4.3 from the table the cost for the production of the prototype can estimated as Rs.13,617 which includes all kind of expenses and the material cost. The prototype dimensions are scale down in the ratio of 1:2.

Table 4.3 Cost statement

Particulars	Amount (Rs.)	Amount (Rs.)
Manufacturing cost		
Materials	6,957	
Labour cost	1,360	
Consumables stores & spares	1,000	
Power & fuels	800	
Miscellaneous expenses	3,500	13,617

PAYBACK PERIOD

In this project the payback can be obtained by means of the reduced time consumption and also due to the reduced manpower. The time required for the fixing of die inside the mould cavity is reduced so the die fixing time get reduced and also the labour cost reduced. In the existing model there is three people worked continuously for four hours then only the die can be fixed in the mother mould. In the conceptual model it get reduced and the cost can be reduced and cost saved can be considered as the payback.

REFERENCES

- [1] Bureau of Indian Standards. (2002) 'Method designation of mechanical and hydraulic presses', 2nd edition, IS 8064:2002.
- [2] Kenneth, G.B. and Michael, K. B. (2009) '*Engineering materials properties and selection*' 9th edition, PHI Learning Private Limited, pp.433-460, ISBN: 978-81-203-3834-0.
- [3] Kottiswaran, N. (2010) '*Engineering mechanics statics and dynamics*' 10th edition, Sri balaji publications, pp.700-720.
- [4] P.S.G DATABOOK (2010).